

AS515 MTM In-Wall Cinema Speaker

Congratulations on your purchase of the AudioSource AS515 MTM In-Wall Cinema Speaker. This product is designed to reproduce the audio portion of your home entertainment system with accuracy and detail that will satisfy the most discriminating listener.

Please read this Installation Manual to ensure the proper installation and performance of your AS515 speaker.

Preparing for your Installation

Gather the necessary tools for your installation.

You will need the following tools:

- 1) A Keyhole or Drywall Saw
- 2) A Phillips Screwdriver
- 3) Masking Tape
- 4) A Pencil
- 5) A Bubble or Laser Level
- 6) A Tape Measure
- 7) A Stud Finder (recommended)
- 8) Your AS515 Speaker

Placement

Plan your speaker placement carefully. Make certain that electrical, plumbing and any other services will not interfere within the walls where you plan to place your speakers. The AS515 speakers can be mounted in the walls or in the ceiling, but are typically used in walls as a stereo pair (see fig. 1). They are also used as a center channel, or as a Left, Center, Right configuration.

In most modern buildings the wall studs are positioned on 16" centers, providing a space between the studs of approximately 14 3/8". The AS515 requires a mounting hole 6 7/8" wide and 13 15/16" high. Additionally, you should allow an extra inch in all directions behind the wall surface to allow room for the doglegs that retain the frame to the wall surface to swing into position. Use a stud finder to locate the vertical studs behind the wall surface. You should now check for obstructions like cross bracing

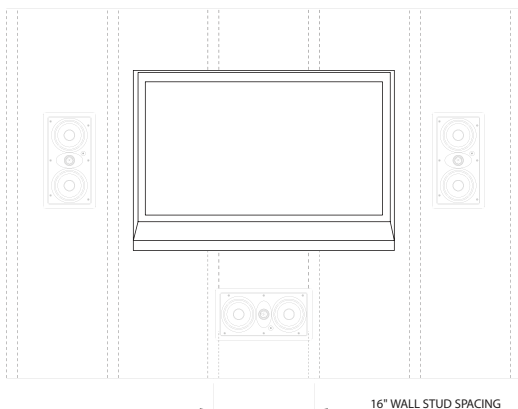

Figure 1

above and below the desired speaker location. After selection of the mounting location, mark the hole to be cut out. A handy cardboard template is included with your AS515 speaker for your convenience. Locate and level the template, then mark with pencil on the wall surface. If you are unsure whether there are obstructions behind the wall surface where the speakers are to be mounted, cut a small hole in the center of your marked mounting location. Holding your drywall saw at a 45 degree angle (see Fig. 2) cut a square hole that you can use to find any obstructions, should they exist.

Once it has been determined that there are no obstructions, cut the hole to mount the speaker using the drywall saw at a 90 degree angle to the wall surface. Cover the raw edges of the wallboard with masking tape (see Fig. 3). This will prevent the back pressure of the speaker from blowing loose gypsum dust out and onto the painted wall surface after installation. Do not allow the tape to extend more than 1/2" beyond the edge of the hole into the room. The frame of the AS515 will cover and hide the tape.

Next, run your speaker wire to your speaker locations. UL rated, CL3 speaker wire is recommended when running wire inside your walls (such as Phoenix Gold Innovative Home SS162W*); In many areas it may be required by code. When running your speaker wire you should avoid having the speaker wire run parallel to the 110V power lines to avoid picking up hum and interference from the power service. If the speaker wire needs to cross a 110V power line, place it at a right angle to the 110V line to minimize any hum or interference.

If you are uncomfortable with running the speaker wire yourself in existing construction, it is recommended that you retain a qualified custom home installation specialist or electrician.

*Available in 3 convenient lengths: 50' mini-spool (M1650W), 100' mini-spool (M16100W), and 250' bulk spool (SS162W/250).



Figure 2

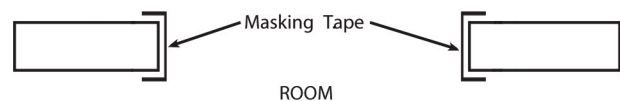

Figure 3

Installing the AS515

It is now time to connect the speaker wire to the AS515. Your speaker wire is usually coded to maintain proper system phasing. This can be by color coding, or one conductor may have a printed marking or a rib along one edge that will not be found on the other. Identify which type of polarity coding that your wire is using. You must carefully observe that the positive terminal of the speaker output on your amplifier is connected to the positive terminal of the AS515 speaker. Likewise, the negative terminal of the amplifier's speaker output should be connected to the negative terminal of the AS515 speaker (Fig. 4).

Installation Tip! To further enhance the performance of your AS515 speakers, the wall stud cavity where you plan to place your speakers can be stuffed with a generous quantity of fiberglass insulation. If un-insulated, stuff the area above and under the speaker opening with 6" thick insulation to a depth of approximately 2 feet beginning 1 foot above and 1 foot below the speaker opening. If the insulation is foil or paper backed, face the backing away from the AS515 speaker. The addition of this insulation will help prevent the unwanted transfer of sound into the large and resonant cavity of the un-insulated wall.

Next, make sure that the doglegs are positioned inside the frame of the speaker (Fig. 5).

With the grill removed, place the speaker in the wall opening. Make sure that the speaker wire is not hanging against the speaker where it can vibrate and rattle as the speaker reproduces your music.

Next, one at a time, turn each of the six screws (Fig. 6) that operate the doglegs counter clockwise a few turns until you feel the dogleg is loose from its resting position. Now turn the screw clockwise until you feel the dogleg contact the wall surface.

Tighten all six of the mounting screws in the same manner until the speaker is properly aligned and held securely to the wall surface. **Caution: Do not over-tighten!**

Painting the Speaker

A paint shield is included in the AS515 speaker package. Place the paint shield inside the frame to protect the speaker. You can now safely paint the speaker frame to match your wall surface if you desire.

When painting the grill caution should be taken to ensure that paint does not clog or block the perforated openings in the grill. This would prevent full operation from the speaker.

Aiming the Tweeter

Using your fingertips, place them carefully at the edges of the tweeter housing. Apply gentle pressure to swivel the tweeter to aim the axis toward the listening area. You can use a piece of music with a solid center imaged vocalist to assist in correctly aiming the tweeter. When the tweeters are properly aligned for the listening area you will hear a coherent and stable center image from your listening position.

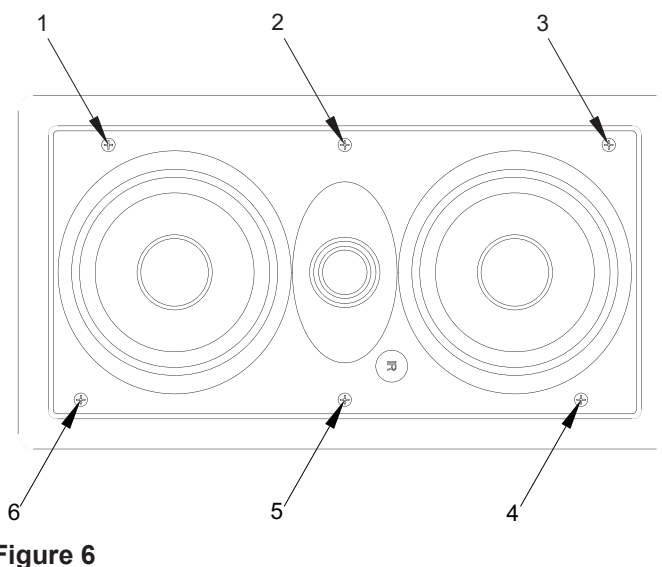
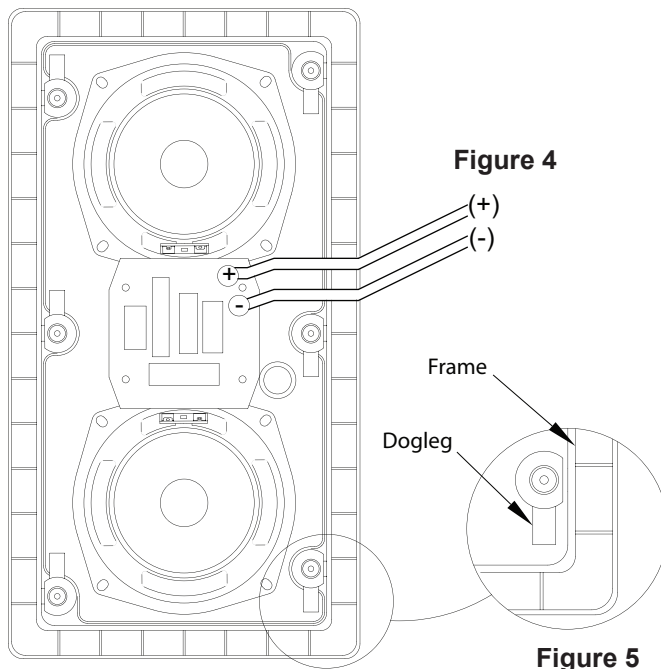

Removing the AS515 Speaker

Should it ever become necessary to remove the AS515 speaker from the wall, simply remove the grill and turn the six mounting screws counter-clockwise until the doglegs lock out of position in their resting seats.

Grill removal

The grill uses a pressure fit relying on the contact of both surfaces to hold it in place. If the grill becomes distorted it becomes difficult to remove or reinstall. Proper care should be taken to not distort its shape while removing it.

If the speaker is not yet installed

While looking at the motor structure (rear) of the speaker assembly, rotate two of the opposing mounting legs outward and then evenly press them towards the grill. This should push the grill out so that you can remove it (Fig. 7).

If the speaker is installed

Locate a small hook tool available at most auto parts stores or home improvement shops resembling a dentists pick (a bent paper clip or stiff wire will work as well), hook your chosen device into the metal mesh of the grill near a corner/ edge and gently pull it towards you, once it moves a slight bit make certain you change positioning of the hook to another location to pull from so you do not distort the grill (Fig. 8). DO NOT PRY ON THE GRILL!

Recommended Speaker Wire Gauges

The resistance of the speaker wire in your installation can cause your speaker to perform at less than an optimum quality level. Excess resistance, caused by using an undersized speaker wire, can result in loss of detail and definition in the low frequency region of your audio program, as well as a loss of dynamic range.

To prevent this effect in your installation, we have recommended speaker wire gauges that should not exceed 0.5 Ohms resistance over the recommended length of wire run.

For the AS515 speaker, we suggest the following minimum speaker wire gauge be used:

50' or less – 16 Gauge 2-Cond. CL3 (PG model M1650W)
50' – 100' – 16 Gauge 2-Cond. CL3 (PG model M16100W)

AS515 SIDE VIEW

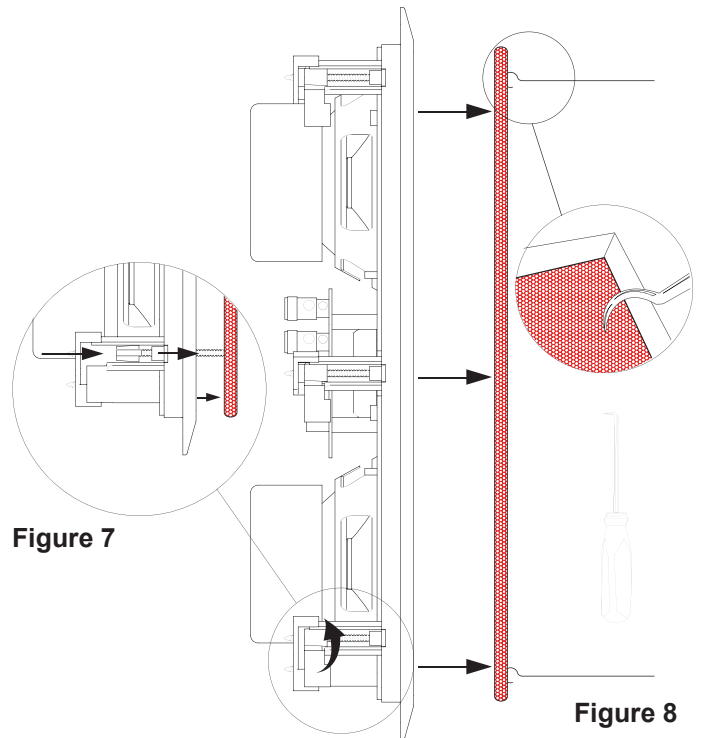

AS515 Specifications

| | |
|------------------------------|--|
| Woofers | 5.25" Poly Cone w/Butyl Rubber Surround |
| Tweeter | 1" Fabric Dome |
| Frequency Response | 60 Hz to 20 kHz |
| Impedance | 8 Ohm |
| Sensitivity | 90dB@2.83V |
| Recommended Amp Power | 25 to 150 Watts Continuous |
| Outer Dimension | 15 3/8" x 8 5/16" (390mm x 210mm) |
| Cut Out Dimension | 13 15/16" x 6 7/8" (354mm x 175mm) |

Two Year Limited Warranty

AudioSource, a division of Rodin, warrants this product against defects in materials and workmanship for a limited period of time. For a period of two (2) years from date of original purchase, we will repair or replace the product, at our option, without charge for parts. Customer must pay for all labor charges associated with the removal and re-installation of speakers for the limited period and all parts and labor charges after the limited warranty period expires. The limited warranty period for factory refurbished products expires after ninety (90) days from date of original purchase. This limited warranty applies only to purchases from authorized AudioSource Retailers or Distributors. This limited warranty is extended only to the original purchaser and is valid only for consumers in the United States.

Consumers are required to provide a copy of the original sales invoice from an authorized AudioSource Retailer or Distributor when making a claim against this limited warranty. This limited warranty only covers failures due to defects in materials or workmanship that occur during normal use. It does not cover failures resulting from accident, fire, flood, misuse, neglect, mis-handling, mis-application, alteration, faulty installation, modification, service by anyone other than AudioSource, or damage that is attributable to Acts of God. It does not cover costs of transportation to AudioSource or damage in transit. The customer should return their defective product, freight prepaid and insured, to AudioSource only after receiving a Return Authorization.

Repair or replacement under terms of this warranty does not extend the term of this warranty. Should a product prove to be defective in workmanship or material, the consumer's sole remedies will be repair or replacement as provided under the terms of this warranty. If the defective product is discontinued AudioSource may replace the product with an equivalent or superior product at its option. Any cost of re-installation or repair of wall or ceiling surface is the sole responsibility of the customer and that cost shall not be the responsibility of AudioSource. Under no circumstances shall AudioSource be liable for loss or damage, direct, consequential or incidental, arising out of the use of or inability to use the product. There are no express warranties other than described above.



Audiosource. 9200 North Decatur Street Portland, Oregon 97203
Tel: 503.286.9300 Fax: 503.978.3381 Tech Support: 800.950.1449
Web: www.audiosource.net Email: support@audiosource.net